

Yale®

Electric
PoweredERP-030TH
ERP-035TH
ERP-040TH

Yale ERP-TH electric trucks are available in 3,000, 3,500, and 4,000 pound capacities and designed for demanding applications that require clean, quiet running, heavy-duty capabilities. These trucks are extremely maneuverable and offer plenty of power and high stacking ability, while also offering excellent ergonomics, reliability and maintenance ease.

AC Transistor Traction Control AC technology offers smooth acceleration with more responsive direction change, proportional regenerative braking and the Auto Deceleration System. The controller converts DC battery power to three phase AC power, and adjusts frequency and current to meet performance demands. Performance control settings and extensive diagnostics are accessible by technicians through the dash display or a PC. The control system utilizing CANbus technology monitors and controls key truck components and systems. The thermal protection system monitors component temperature and gradually adjusts performance to prevent damage to key components.

Controller Area Network (CANbus) CANbus technology streamlines communications between truck systems. Dash display, traction controller and optional pump controller are all controlled via the CANbus network. A connection point is provided for interface with a service PC.

Electrical System The ERP-TH utilizes AC motor technology designed for exceptional performance. It uses a brushless induction motor for high starting torque and smooth rapid acceleration. Speed sensors built into the motors provide feedback to the control system, allowing motor speed and direction to be continuously monitored. A thermal management system controls the power delivered to the motors during stall conditions, thereby protecting them from damage.

Dual drive motors Dual drive motors are designed specifically for the ERP-TH and are individually mounted for easy servicing. Each 8.1" diameter motor is a long stack design for high torque and is designed to withstand high temperatures.

Hydraulic System The standard hydraulic configuration on the ERP-TH utilizes a simple contactor DC system offering a low initial cost solution for standard duty cycles. Brushwear indicators minimize required maintenance. This system is equipped with a thermal sensor to avoid overheating. The standard hydraulic pump is designed for quiet operation.

Transistorized Hydraulic System (optional) An optional transistor control hydraulic system provides quiet operation, extended component life and maximum battery run time. A gradual start-up speed increases brush life and minimizes wear on hydraulic components. The pump delivers the proper amount of oil for truck functions based on operator input. Transistorized hydraulics are required on trucks equipped with cold storage/corrosion packages and "EE" UL Construction.

Hydraulic Control Levers The standard hydraulic control levers are located on the right-hand side of the seat within easy reach of the operator. With the main control valve located just to the right of the operator's seat there is no leaning, bending or reaching out to activate the

hand levers; reducing operator fatigue. The levers are ergonomically shaped and positioned for quick, accurate hand placement and lever actuation. Levers are contour-molded to maximize grip and minimize required force.

Electro-Hydraulic Control Levers (optional)

Optional electro-hydraulics provide a new level of operator comfort with fingertip control of hydraulic functions, including an adjustable padded armrest for individual preferred positioning. The electro-hydraulic controls are available in both three-way and four-way configurations. This option offers the ability to control multiple functions simultaneously. The armrest tilts up and out of the way allowing convenient entry and exit from either side of the truck. This option is used with transistor hydraulics and is the most productive combination in terms of ergonomics and operating cost savings.

Foot Direction Control Pedal (FDC) (optional)

The optional FDC is a highly productive directional/accelerator pedal. One pedal allows the operator to change direction and accelerate reducing operator movement and resulting in increased productivity.

Standard Dash Display The standard dash display is mounted on the dash to the right of the steering column. The display features 20-segment LCD battery discharge indicator with lift interrupt, brushwear indicator, thermal sensor, hour meter, and warning lights for seat belt, parking brake, and service brake fluid. Additional capabilities include comprehensive diagnostics and a programmable service maintenance monitor. A 40-character display provides clear, concise messages that are easy to read.

Premium Dash Display (optional) The optional premium dash display with diagnostic readout has all the basic instrumentation that is on the standard display. Additional capabilities include multiple operator password capability, four selectable operator performance modes, a pre-shift operator checklist, and a programmable service maintenance monitor.

Steering Column

The steering column is adjustable to five tilt positions to accommodate the operator. It is mounted high on the cowl to provide additional operator clearance. Lock-to-lock steering requires five revolutions of the wheel. The truck is equipped with a direction lever on each side of the steering column. A 14" steering wheel is standard. A compact 12" steering wheel with a spinner knob is optional.

Hydrostatic Power Steering

The on-demand hydrostatic power steering system is standard and features a brushless steer motor that requires no maintenance. This system pro-

vides precise control with low effort and exceptional maneuverability.

Steer Axle The steer axle is one piece-forged steel and is mounted to a rack and pinion hydraulic actuator. The actuator is mounted to the rear frame reinforced support plate. The hydraulic actuator is totally enclosed for protection from dirt and debris.

Twin Steer Tires The standard twin steer tires are made of special compounds to complement the drive tires and provide acceptable load handling capacity and low energy consumption. Twin steer tires provide long tire life while providing the operator with a more comfortable ride.

Dual Transaxles The dual transaxles are independently controlled for optimization of power and maneuverability. Power transfer occurs via gear reduction in addition to planetary drives for a final reduction ratio of 26:1.

Drive tires and steer tires The drive tires and steer tires are available in solid pneumatic and optional solid cushion. Tire removal can be performed quickly with the removal of five mounting nuts. Various tire options to suit the particular application are available.

Dual Wet-Disc Brake System The ERP-TH is equipped with a dual wet-disc brake system mounted within the drive unit assemblies and is actuated hydraulically by the brake pedal. The brake discs are bathed in oil for cooling and reduced wear. This system provides exceptional brake service life with no adjustments, no maintenance and excellent stopping power. This system is sealed and impervious to water and debris resulting in dependable braking. A large brake pedal is positioned for use by either foot. The sealed master cylinder reservoir contains a sensor, which lights

(continued on back page)



Truck shown with optional equipment

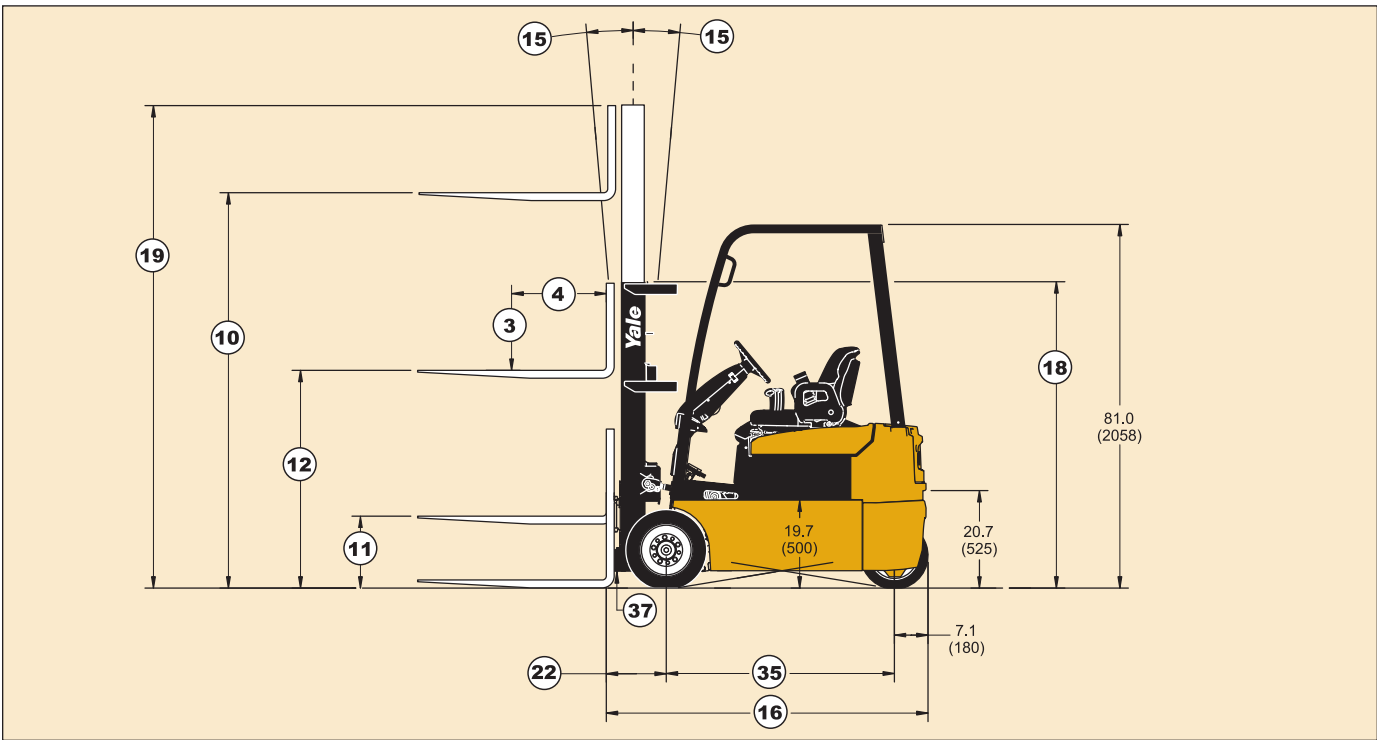

GENERAL	1	Manufacturer	Manufacturer's Name	YALE		
	2	Type	Manufacturer's Capacity	3-Wheel Rider Electric		
	3	Capacity	Rated Capacity	lb. (kg)	3000 (1600)	
	4	Load Center	Distance	in. (mm)	24 (610)	
	5	Power Type		Electric		
	6	Operator Type	Pedestrian, Stand-on, Seated Rider	Sit-Down		
	7	Step Height		in. (mm)	19.7 (500)	
	8	Tire Type	Cushion, Solid, Pneumatic, etc.	Solid		
	9	Wheels	Number - Front/Rear	2x1 Dual		
DIMENSIONS	10	Lift Height with	Lift Height (Top of Fork)	in. (mm)	119.4 (3032)	
	11	Two Stage Mast	Standard Free Lift (Top of Fork)	in. (mm)	5.5 (140)	
	12		Optional Free Lift (TOF) w/ w/o LBR	in. (mm)	29.9 (757) / 55.4 (1406)	
			Maximum Carriage Width	in. (mm)	38.5 (977)	
	13	Forks	Thickness/Width/Length	in. (mm)	1.5 x 4 x 42 (40 x 100 x 1066)	
	14	Fork Spread	Outside Dimensions	in. (mm)	37.7 (958)	
	15	Tilt of Mast	Forward/Backward	degrees	5 / 7	
	16		Length to Face of Forks	in. (mm)	71.2 (1808)	
	17		Overall Width	in. (mm)	41.0 (1040)	
	18	Overall Dimensions	Height with Collapsed Mast	in. (mm)	78 (1981)	
	19		Height with Extended Mast With LBR	in. (mm)	167.5 (4255)	
	20		Height of Overhead Guard	in. (mm)	81.0 (2058)	
	21	Turning Radius	Outside	in. (mm)	57.9 (1470)	
	22	Distance	Center of Wheel to Face of Forks	in. (mm)	13.3 (339)	
	23	Aisle Width	Rt. Angle Stack (Add Length of Load)	in. (mm)	71.6 (1818)	
	24	Equal Aisle		in. (mm)	61.9 (1572)	
PERFORM.		Stability	*Comply with ANSI?	Yes		
		Voltage		36	48	
	25	Speeds	**Std. Travel Speed: No Load/With Load	mph (km/h)	8.0 (12.9) / 7.6 (12.2)	8.8 (14.2) / 8.1 (13)
	25a		Max. Travel Speed: No Load/With Load	mph (km/h)	8.8 (14.2) / 8.6(13.8)	8.8 (14.2) / 8.6(13.8)
	26		Lift Speed: No Load/With Load	ft/min (m/s)	95 (.48) 68 (.35)	115 (.58) 85 (.43)
	27		Lowering Speed: No Load/With Load	ft/min (mm/s)	93 (4724) /100 (5080)	93 (4724) / 100 (5080)
28	Drawbar Pull	No Load/With Load (60 minute rating)	lb.	744 / 691		
WT.	30	Steering	Type	Hydrostatic		
	31	Unloaded Weight	Standard Truck (w/o Battery)	lb. (kg)	5100 (2313)	
	32	Axle Loads	With Load - Front/Rear (Maximum Battery)	lb	9050 / 1550	
	33	Tire Size	Front	18 x 7-8		
	34		Rear	15 x 4.5 x 8		
	35	Wheelbase	Distance	in. (mm)	50.8 (1290)	
	36	Tread	Center of Tires - Front	in. (mm)	34.0 (864)	
	37	Ground Clearance	No Load at Lowest Point	in. (mm)	3.5 (89)	
	38		No Load at Center of Wheelbase	in. (mm)	4.0 (100)	
	39	Brakes	Service	Hydraulic		
40	Parking		Spring Applied/Electrically Released			
BATTERY		Battery Compartment	in.	39 x 21.5 x 26.12		
	41	Battery	Type	Lead Acid		
	42		Amphere Hrs 36/48-Volts	amp/hr	880 / 660	
	43	Battery Weight, min/max		lbs.	1700 / 2500	
	48	Traction Control Type			Transistor	
	49	Hydraulic Control			Contactor / Transistor	
50	Hydraulic Pressure		psi	2600		

* Based on triplex mast with maximum weight **Extended shift enabled

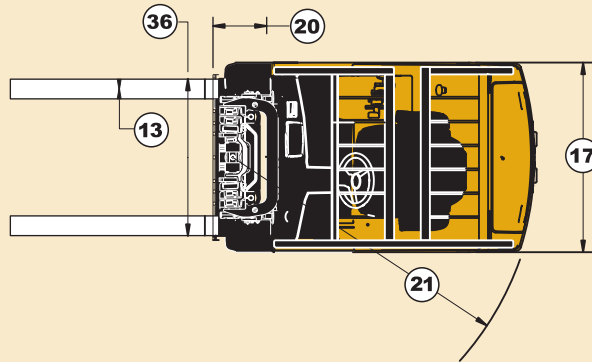

YALE		YALE		1	GENERAL
3-Wheel Rider Electric		3-Wheel Rider Electric		2	
3500 (1800)		4000 (2000)		3	
24 (610)		24 (610)		4	
Electric		Electric		5	
Sit-Down		Sit-Down		6	
19.7 (500)		19.7 (500)		7	
Solid		Solid		8	
2x1 Dual		2x1 Dual		9	
119.4 (3032)		119.4 (3032)		10	
5.5 (140)		5.5 (140)		11	
29.9 (757) / 55.4 (1406)		29.9 (757) / 55.4 (1406)		12	
38.5 (977)		38.5 (977)			
1.5 x 4 x 42 (40 x 100 x 1066)		1.5 x 4 x 42 (40 x 100 x 1066)		13	
37.7 (958)		37.7 (958)		14	
5 / 7		5 / 7		15	
74.9 (1902)		74.9 (1902)		16	
41.0 (1040)		41.0 (1040)		17	
78 (1981)		78 (1981)		18	
167.5 (4255)		167.5 (4255)		19	
81.0 (2058)		81.0 (2058)		20	
61.6 (1565)		61.6 (1565)		21	
13.3 (339)		13.3 (339)		22	
75.4 (1914)		75.4 (1914)		23	
63.3 (1609)		63.3 (1609)		24	
Yes		Yes			
36	48	36	48	25	
8.0 (12.9) / 7.4 (11.9)	8.8 (14.2) / 8.1 (13)	8.0 (12.9) / 7.2 (11.6)	8.8 (14.2) / 7.9 (12.8)	25a	
8.8 (14.2) / 8.6 (13.8)	8.8 (14.2) / 8.6 (13.8)	8.8 (14.2) / 8.6 (13.8)	8.8 (14.2) / 8.6 (13.8)	26	
95 (.48) / 65 (.335)	115 (.58) 80 (.41)	95 (.48) / 60 (.31)	115 (.58) / 75 (.38)	27	
93 (4724) / 100 (5080)	93 (4724) / 100 (5080)	93 (4724) / 100 (5080)	93 (4724) / 100 (5080)	28	
733 / 672		733 / 663		30	
Hydrostatic		Hydrostatic		31	
5150 (2336)		5150 (2336)		32	
9860 / 1590		10,700 / 1250		33	
18 x 7-8		200/50-10		34	
15 x 4.5 x 8		15 x 4.5 x 8		35	
54.5 (1385)		54.5 (1385)		36	
34.0 (864)		34.2 (869)		37	
3.5 (89)		3.5 (89)		38	
4.0 (100)		4.0 (100)		39	
Hydraulic		Hydraulic		40	
Spring Applied/Electrically Released		Spring Applied/Electrically Released		41	
39 x 25.2 x 26.12		39 x 25.2 x 26.12		42	
Lead Acid		Lead Acid		43	
1100 / 770		1100 / 770		44	
2100 / 2800		2100 / 2800		45	
Transistor		Transistor		46	
Contactor / Transistor		Contactor / Transistor		47	
2600		2600		48	
				49	
				50	

(continued from front page)

a warning lamp on the dash panel if the fluid level becomes low.

Automatic Electric Park Brakes The standard automatic electric park brakes are spring-applied, electrically released units mounted on the end of the motor shafts. The brake assemblies automatically apply whenever the traction motors come to a stop and traction is not requested, or the seat switch is released when the operator leaves the seat. The brakes are electrically released only after a direction has been selected and the accelerator has been depressed. The brake units require no adjustments and do not wear from normal use. The parking brakes are designed to hold the truck on a 15% grade with a rated load. A visual warning indicates when brakes are applied.

Frame The frame is computer designed and tested using the latest finite element analysis techniques for structural integrity. The truck has a three-piece floor plate that can be easily lifted out for service access without the use of tools. A unique suspended counterweight cover opens out to provide exceptional access to electrical components. An ABS thermal formed plastic, gas-spring-assisted battery cover allows easy changing of the battery. The battery compartment can be fitted with the optional side entry rollers or slides.

Seat The operator's seat is well positioned for easy entry and exit. The non-suspension vinyl seat with anti-cinch seat belt and hip restraints is standard. All seats are equipped with a sensing switch allowing truck operation only when the seat is occupied. These seats feature six inches of fore and aft movement. Optional semi-suspension and full-suspension with seat belt and hip restraints are available. These seats can accommodate the optional electro-hydraulic control featuring a fully adjustable armrest and wrist support for use with the ergonomic fingertip controls.

Standard Lift Specifications

Model	O.A.H. In	Free Fork Ht In	Max Fork Ht In	Tilt Rwd-Fwd Degrees	Drive. Tire Size	O.A.W. In
ERP030TH Simplex	72	5.5	107	7°-5°	18 x 7-8	41.0
	82	5.5	127	7°-5°	18 x 7-8	41.0
	94	5.5	151	7°-5°	18 x 7-8	41.0
Duplex	72	*49.4	109	5°-5°	18 x 7-8	41.0
	78	*55.4	121	5°-5°	18 x 7-8	41.0
	82	*59.3	129	5°-5°	18 x 7-8	41.0
	94	*71.1	153	5°-5°	18 x 7-8	41.0
Triplex	72	*49.4	159	5°-5°	18 x 7-8	41.0
	78	*55.4	177	5°-5°	18 x 7-8	41.0
	82	*59.3	189	5°-5°	18 x 7-8	41.0
	94	*71.1	218	5°-5°	18 x 7-8	41.0
ERP035TH Simplex	72	5.5	107	7°-5°	18 x 7-8	41.0
	82	5.5	127	7°-5°	18 x 7-8	41.0
	94	5.5	151	7°-5°	18 x 7-8	41.0
Duplex	72	*49.4	109	5°-5°	18 x 7-8	41.0
	78	*55.4	121	5°-5°	18 x 7-8	41.0
	82	*59.3	129	5°-5°	18 x 7-8	41.0
	94	*71.1	153	5°-5°	18 x 7-8	41.0
Triplex	72	*49.4	159	5°-5°	18 x 7-8	41.0
	78	*55.4	177	5°-5°	18 x 7-8	41.0
	82	*59.3	189	5°-5°	18 x 7-8	41.0
	94	*71.1	218	5°-5°	18 x 7-8	41.0
ERP040TH Simplex	72	5.5	107	7°-5°	200/50-10	42.4
	82	5.5	127	7°-5°	200/50-10	42.4
	94	5.5	151	7°-5°	200/50-10	42.4
Duplex	72	*49.4	109	5°-5°	200/50-10	42.4
	78	*55.4	121	5°-5°	200/50-10	42.4
	82	*59.3	129	5°-5°	200/50-10	42.4
	94	*71.1	153	5°-5°	200/50-10	42.4
Triplex	72	*49.4	159	5°-5°	200/50-10	42.4
	78	*55.4	177	5°-5°	200/50-10	42.4
	82	*59.3	189	5°-5°	200/50-10	42.4
	94	*71.1	218	5°-5°	200/50-10	42.4

* Without backrest - with backrest subtract 48 inches from mast overall height. Capacity, tire, and tilt specifications apply only to the mast sizes shown. All capacities are with 42" forks. For information on other masts, contact Applications Engineering, Greenville, North Carolina.

Entrance/Exit Step A wide-open step with anti-skid surface located on the left side is 20" from the ground. A rubber-coated handgrip located on the left-hand overhead guard provides easy entrance to the operator compartment. A 20" right-hand step is included with the electro-hydraulic control option. The armrest on the electro-hydraulic control tilts up and out of the way for convenient right side entry and exit.

Floor Plate The three-piece floor-plate design allows quick access to the motor compartment. A thick cushioned floor mat is standard and provides additional comfort and helps to ensure solid footing. The floor plates can be removed without the use of tools and include locator pins for easy installation. Integral hand grips offer easy handling of the plates while allowing additional ventilation and access for lubricating tilt cylinder pins. The tilt cylinders are placed beneath the floor plate for uncluttered foot space.

Masts/Carriage/Forks/Load Backrest Extension Yale Global Hi-Vis simplex, duplex, and triplex masts provide excellent visibility. The mast features flush face design with geometrically matched, angled load rollers, which are canted, yet provide full-face roller contact. The mast front rail flange angle coupled with the inverted "J" inner channel and 3-degree mast rollers significantly reduces channel web milling and roller wear. Trunnion mounts have replaceable bushings for longer life. The standard Class II carriage features pre-lubed and sealed full radius, angled load rollers that resist forward, backward, and lateral forces. Forks are "upset forged" from a single piece of high strength steel to give strength and added thickness for wear. A 48" load backrest extension is standard. An optional integral sideshifter is available on the ERP-TH. Various internal and external auxiliary function hose groups are available.

Overhead Guard The overhead guard has an overall height of 81" providing increased headroom. The upright bars are contoured to provide optimal entry and egress. Rolled steel crossmembers and fore and aft reinforcing bars provide additional strength and excellent visibility. The overhead guard features a

right side battery removal slot design for the use with an overhead chain hoist. The overhead guard is available in an optional low profile height of 78". An optional 81" drive-in rack overhead guard is also offered.

Options

- DC transistor hydraulics
- Electro-hydraulic controls
- Premium dash display
- Integral sideshifter
- Cold storage packages
- Semi-suspension seats
- Full suspension seats
- Battery sliders
- Overhead guard mounted headlights
- 78" overhead guard
- Drive-in rack overhead guard
- Various light packages
- Various mast heights
- 10° forward tilt
- 48 volt
- Foot Directional Control Pedal
- Alarm - Back-up (82 - 102 dBA)
- Light - Amber strobe
- Type "EE" UL Construction

Truck performance may be affected by the condition of the vehicle, how it is equipped and the application. Consult your Yale Industrial Truck Dealer if any of the information shown is critical to your application. Specifications are subject to change without notice.

This truck meets all design specifications of ANSI B56.1 Safety Standard for Powered Industrial Trucks at the time of manufacture. Classified by Underwriters' Laboratories, Inc. as to fire hazard only for type "E" and optional "EE" for industrial trucks.

Lift and Lower Speeds, ft/min (m/s)

Model	Lift Speed 36-Volt Empty/Loaded	Lift Speed 48-Volt Empty/Loaded	Lower Speed 36- and 48-Volt Empty/Loaded
ERP030TH	Simplex ft./min. (m/s)	95/68 (.48/.35)	115/85 (.59/.43)
	Duplex ft./min. (m/s)	90/63 (.46/.32)	110/80 (.56/.41)
	Triplex ft./min. (m/s)	90/63 (.46/.32)	110/80 (.56/.41)
ERP035TH	Simplex ft./min. (m/s)	95/65 (.48/.33)	115/80 (.59/.41)
	Duplex ft./min. (m/s)	90/60 (.48/.30)	110/75 (.56/.38)
	Triplex ft./min. (m/s)	90/60 (.46/.30)	110/75 (.56/.38)
ERP040TH	Simplex ft./min. (m/s)	95/60 (.48/.30)	115/75 (.59/.38)
	Duplex ft./min. (m/s)	90/55 (.46/.28)	110/70 (.56/.36)
	Triplex ft./min. (m/s)	90/55 (.46/.28)	110/70 (.56/.36)

Battery and Compartment Specifications

Model	Compartment Size			Battery Specifications									
				Size			Electrical			Weight*			
	Dim X	Dim Y	Dim Z	Dim "X" Min	Dim "X" Max	Dim "Y" Min	Dim "Y" Max	Dim "Z" Max	Volts	Plates Max	Min	Max	
ERP030TH	39.0	21.5	26.12	38.1	38.7	20.0	21.2	22.8	36	17	880	1900	2300
				38.1	38.7	20.0	21.2	22.8	36	17	800	2000	2500
				38.1	38.5	20.0	21.2	22.8	48	13	660	2000	2300
				38.1	38.5	20.0	21.2	25.8	48	13	600	2000	2500
ERP035/40TH	39.0	25.2	26.12	38.4	38.8	23.5	25.0	22.8	36	21	1000	2100	2650
				38.4	38.8	23.5	25.0	25.8	36	21	1000	2500	2800
				38.4	38.8	23.5	25.0	22.8	48	15	770	2350	2650
				38.4	38.8	23.5	25.0	25.8	48	15	700	2500	2800

36-Volt includes SB350 Grey connector, lead position B, STD.39 in. long. 48-Volt includes SB350 Blue connector, lead position B, STD.30 in. long. *Battery weights shown may require an additional counterweight/spacer.



Manufactured in our own ISO 9002 Registered Facilities

Yale Materials Handling Corporation

P.O. Box 7367, Greenville, NC 27835-7367

Copyright 2004, Yale Materials Handling Corporation

2351-2— 4/04—50

Printed in U.S.A.